

Installation Instructions

SERIES A DOORS - up to 3400mm wide

SERIES AA DOORS - 3401mm and wider

PARTS LIST	SERIES AA DOORS	RECOMMENDED TOOLS	* Remote control options only
SERIES A DOORS			
2 25mm Side Tracks	2 50mm Side Tracks	Tape Measure	
2 Mild Steel Mounting Brackets	2 Mild Steel Mounting Brackets	Spirit Level	
2 U Bolts with Nuts	2 U Bolts with Nuts	13mm Socket	
2 Pressed Steel Saddles	2 Cast Iron Saddles	15mm Socket	
16 Washers	16 Washers	Hacksaw	
8 Fixing Lugs	8 M10 x 70mm Coach Screws	Claw Hammer	
8 M10 x 70mm Coach Screws	4 M12 x 70mm Coach Screws	File	
4 M12 x 70mm Coach Screws	2 Gutter Bolts	10mm Masonry Bit	
1 Handle with Fixings	2 Stops	12mm Masonry Bit	
*1 Remote Control Box	1 Handle with Fixings	Orbital Drill Bit	
*1 Steel Balance Weight Bar	*1 Remote Control Box	Stilsons	
*1 Cast Iron Saddle to replace 1 pressed saddle	*1 Steel Balance Weight Bar	Stanley Knife	
*2 Security Screws	*1 Heavy Duty Anchor Bracket with Anchor Tubes	Power Drill	
	*2 Security Screws		

IMPORTANT:
For automatic door installations, these instructions must be read in conjunction with the separate Glidermatic Remote Control Instructions.

1 PREPARATION

DO NOT REMOVE THE PACKAGING UNTIL TENSION HAS BEEN APPLIED TO THE DOOR (see Stage 3, page 2).

Before commencing, measure both the opening and the door curtain and mark the overlap on the wall, ensuring a minimum clearance of 10mm is allowed at each side to facilitate the fixing of brackets and side tracks. This door will be positioned behind the opening, therefore overlap the opening on each side by a minimum of 25mm for Series A doors and 50mm for Series AA doors. For manual doors a minimum of 50mm is required from the edge of the curtain to the side wall for Series A doors, 100mm for Series AA.

Automatic doors require an extra 35mm (minimum) sideroom on the motor side of the curtain.

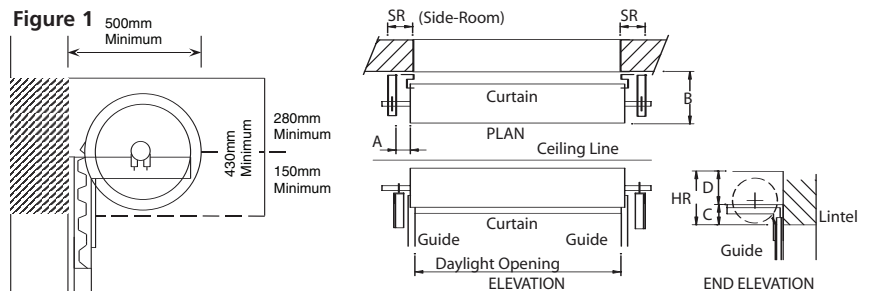

DIMENSION PANEL (minimum sizes) mm							
SERIES A (Hand Operated)	Side Room		Head Room	A	B	C	D
	Resid.A	Resid.AA					
2100 HIGH	90	125	430	25-100	500	150	280
2400 HIGH	90	125	450	25-100	540	160	290
2700 HIGH	90	125	450	25-100	540	160	290
3000 HIGH	90	125	470	25-100	560	170	300

2 AFFIXING MOUNTING BRACKETS

The headroom between the underside of the ceiling/roof truss and the top of the opening/underside of the lintel should be a minimum of 430mm for Series A doors and a minimum of 470mm for Series AA doors. See headroom clearance box (Fig 1). If the recommended headroom is not available the door may still be installed maintaining the required headroom, however some loss of opening height will occur and the roll of the door will be visible. This can be disguised by a fascia. Any excess curtain will remain on the roll.

The top of the slotted bearing surface of the mounting brackets (see Fig. 4, page 2) should be 150mm from the top of the opening/underside of the lintel and a minimum of 280mm from the underside of the ceiling/roof truss. If the recommended headroom is not available the 280mm measurement must be maintained for Series A and Series AA doors (see Fig. 2).

It is important that the outside face (smooth side) of the angle bracket faces the sidewall of the garage. Drill and plug then firmly secure one of the mounting brackets with 50mm coach screws. **N.B. coach screws should not be used without the appropriate wall plug for the material you are fixing to.**

The clearance on either side between the door curtain and mounting brackets is a minimum of 10mm, or a maximum of 75mm **N.B. this does not apply to automatic doors, see Glidermatic installation instructions.**

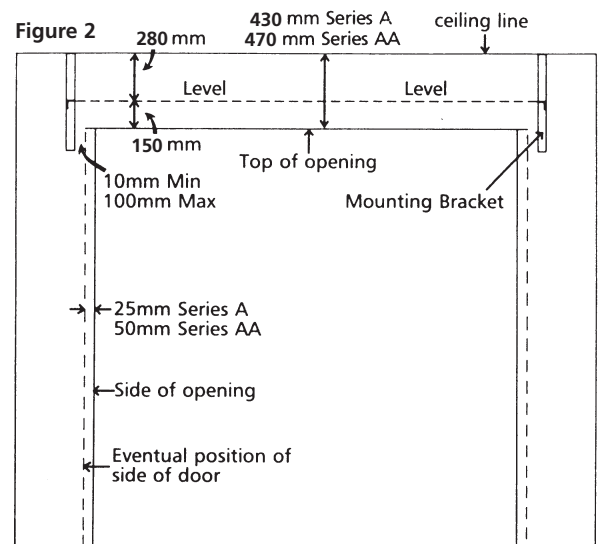

It is vital that the second mounting bracket is positioned with the use of a laser level/spirit level to ensure that THE BRACKETS ARE EXACTLY LEVEL WITH ONE ANOTHER. **Automatic doors require the motor side bracket to be positioned 5mm lower.**

3 POSITIONING THE DOOR

Before lifting ensure that the door is centralised on the axle, so that an equal length of axle is exposed at either end. Measure from the overlap mark on the wall (take in stage 1) to side obstruction (e.g. wall) (see Fig. 2). If sufficient side clearance for the axle is not available the axle may be shortened, ensuring that 50mm remains on either end (for a manual door) with an extra 35mm for an automatic door. IT IS IMPORTANT THAT THE AXLE IS NOT CUT TOO SHORT. Ensure that the door is placed the correct way round on the bracket and that the bottom rail is in the correct position. Figure 4 illustrates the relative position of the bottom rail from a side view perspective (side packaging may be carefully cut away at this stage only to reveal the end of the roll).

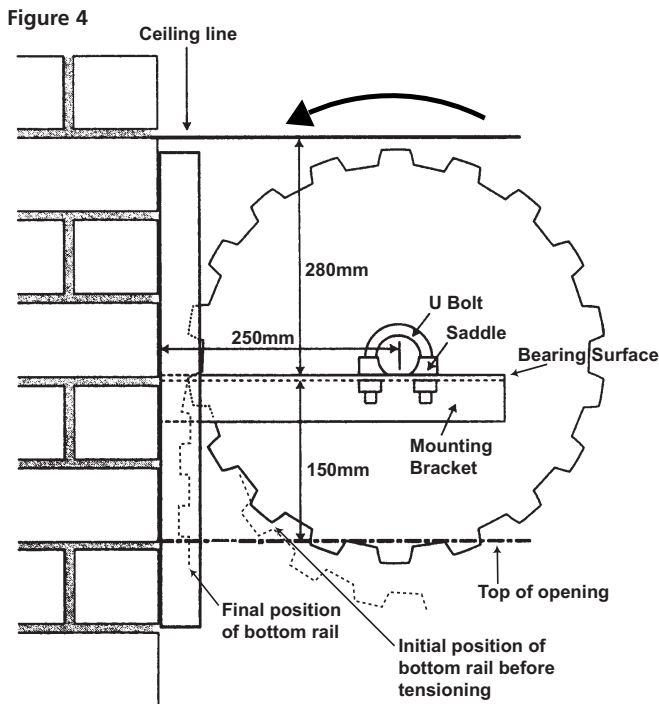
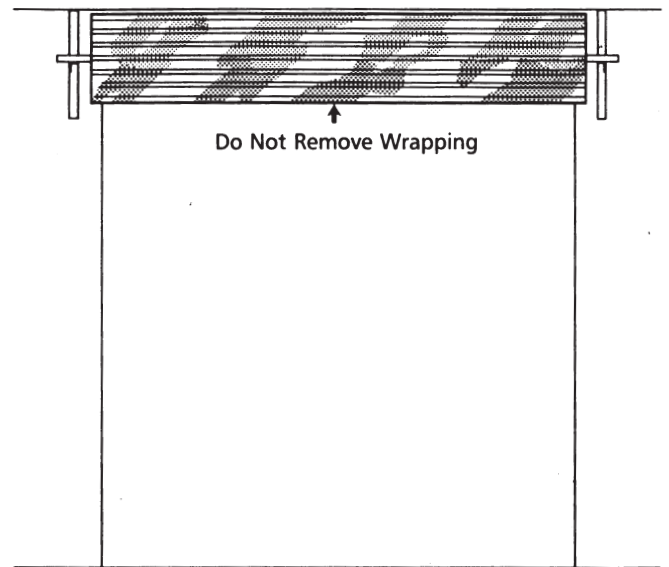

Figure 3



Secure the axle to the mounting brackets with the U bolts and pressed saddles (see Fig. 4 for position). Automatic doors are supplied with 1 cast saddle and 1 pressed saddle (cast saddles are grey, pressed saddles are gold in colour), the cast saddle should be positioned inside the anchor block on the motor side of the door at this stage (see Fig. 5, p. 3 automatic door instructions). LOCK THE U BOLTS TIGHTLY ensuring washers are placed under the nuts.

Spring tension will be lost if the axle is not firmly clamped.

Tension should now be applied to the spring by rotating the door approximately 2 times in a forward direction as shown on Figure 4. The amount of tension required to give the best operation may vary with individual doors and final adjustments should be made upon completion of the installation.

4 UNROLLING THE DOOR

Holding the door in the tensioned position carefully cut the wrapping. **It is important that the door is held firmly at this stage to prevent loss of tension.** Keeping hold of the door pull the door fully open and remove all wrapping.

N.B. The door may have a strong tendency to rise, which, if uncontrolled, can cause damage/injury.

Still holding the door, allow the door to roll up evenly ensuring it is straight on the drum. Place a piece of soft timber, approximately 450mm long, as a choc in between the bottom rail and the drum, as shown in Figure 5, taking care not to damage the door.

Figure 5

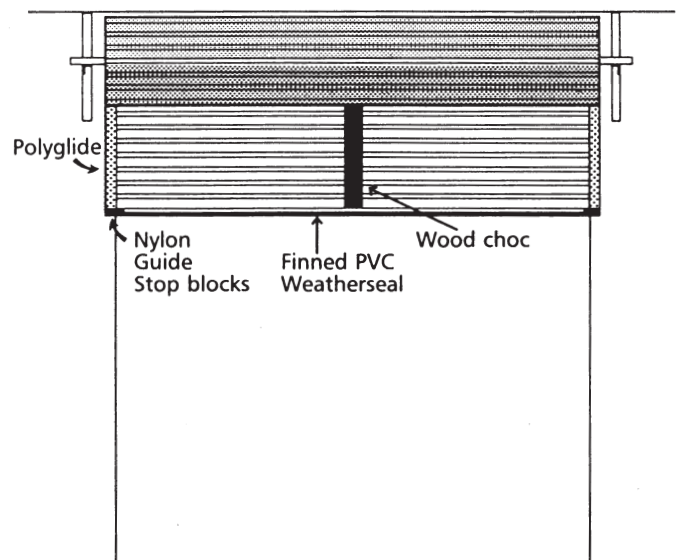

5 FIXING THE SIDE TRACKS

Clean the side tracks with a spirit cleaner.

Using a hammer flatten the top 20mm of the back edge of the top of the track. Using the claw end of the hammer form a curl on the front edge of the track (Fig. 6b). Insert and tap fixing lugs fully into sides of one track at regular intervals. The lowermost lug should be positioned approximately 200mm from the floor (Fig 6a). The bottom of the side tracks **must be** flush with the floor. If the floor is slightly out of level, always work from the higher floor side first.

Ensure that the top of the track is level with the top of the bearing surface of the bracket. Slide the track on to the door curtain allowing 4mm clearance from the edge of the door to the edge of the track, ensuring that the door remains straight. Hold the track in position against the wall and mark, drill, plug and fix the top lug with a 70mm coach screw. NOW USE A SPIRIT LEVEL TO ENSURE THAT THE SIDE TRACK IS VERTICAL and fix the track in position via the remaining lugs ensuring that the bottom lug is approximately 200mm from the floor.

Repeat this process for the second track.

Tracks may require cutting at this stage. **N.B. excess should be cut from the BOTTOM of the track**

With the door positioned within the tracks carefully remove the wood choc (if used). Ensure that the door curtain rolls up evenly and centred within the opening.

PLEASE NOTE: All dimensions given are for guideline purposes only and final adjustments may have to be made depending on the garage specifications.

Figure 6a

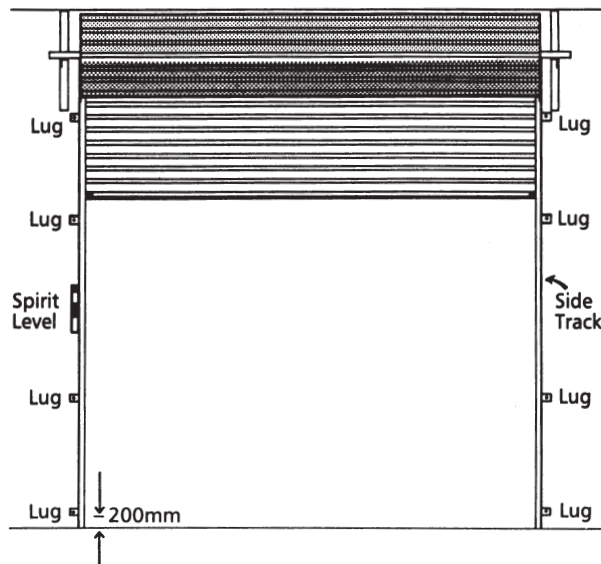
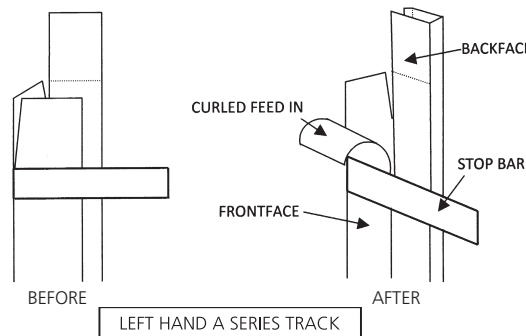

Figure 6b



6 FINAL ADJUSTMENTS

At this stage the door should roll up and down evenly within the tracks. Tracks may be adjusted slightly if necessary.

If the door feels heavy or light when rolling up and down then the tension should be adjusted. The balance of tension on the door should ensure that the door neither rises nor falls of its own accord or is difficult to lift or pull down (see Fig. 7 for instruction on how to increase/decrease tension).

Figure 7

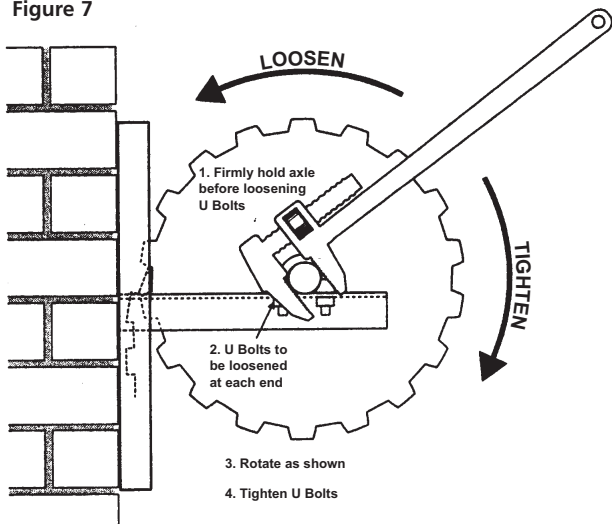

7 FITTING LOCKING BAR

With the door closed and firmly seated on the floor, mark the point of contact of the centre line of the locking bar on each track. Drill a hole in the track using an orbital drill bit to accommodate the locking bar. File edges of hole as required. A neat fit will minimise the vibration and maintain efficiency of the weatherseal.

Affix the lifting handle in the centre of the aluminium bottom rail (do not attach to door curtain). Raise the door to track stop for correct positioning on aluminium bottom rail. Mark, drill and fix with gutter bolts.

Additional stops should be fitted at this stage to AA series doors on the aluminium bottom rail in line with track stop.

GLIDEROL ROLLER DOORS DO NOT REQUIRE LUBRICATION

Figure 8

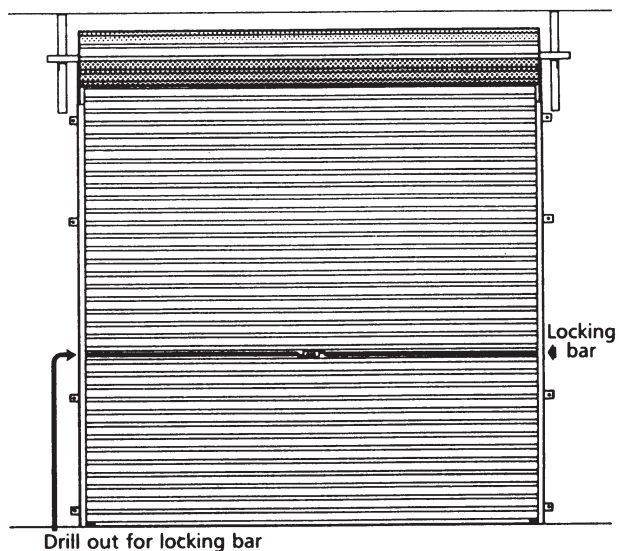

INSTALLATION FAULTS AND REMEDIES

FAULT

Door is difficult to operate in one direction.

Door is difficult to operate in both directions

Door makes a bumping sound during operation.

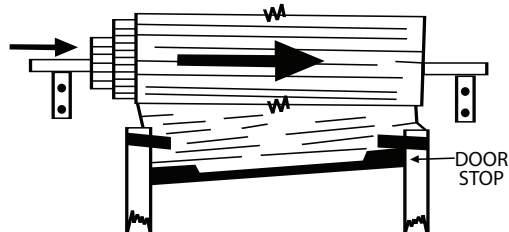

Door rolls up unevenly/bottom rail of door rolls up out of parallel with roll of door/edge of roll is not flush, i.e. door is rolling up in a spiral or cone shape (see diagram above).

REMEDY

Adjust spring tension (stage 6)

Check track clearances to ensure door is not jamming (stage 6).

Check tracks are not too long (stage 5). Ensure door is positioned on brackets the same distance from the lintel/wall at either end of the door. Door must be in open position and adjustment may only be made to one side at a time. Ensure opposite U-Bolt is secure/tight before proceeding, tension will be lost if this procedure is not adhered to. Loosen the U-Bolt and push that side of the door towards the opening as far as possible without scraping the lintel. Tighten U-Bolt and repeat operation with other side, ensuring axle is still parallel with opening (top lug on side track may be packed out).

Check that the mounting brackets are level with one another. Axle may not be in centralised position (see stage 3 and adjust accordingly).

WARRANTY: Electrical Components 2 Years • Mechanical Components 6 Years
Door Finish 10 Years

IMPORTANT WHEN OPERATING GLIDEROL GARAGE DOORS

- 1 In the interest of your safety and that of others, this door must only be operated by competent users familiar with its operation.
- 2 When operating the door do not place fingers near tracks or other moving parts at any time.
- 3 The person operating the door must have the door within their sight at all times during operation.
- 4 Do not allow children to play with the garage door and any associated parts, including electrical controls.
- 5 Do not attach any objects or make any modifications to the door as this may cause damage and/or physical injury.
- 6 Operate the door only when free from obstruction.
- 7 Should the door become difficult to operate or completely inoperable, discontinue use and call a qualified technician. Only experienced door service personnel should undertake repairs and adjustments.
- 8 As polyglide is self lubricated it is important **NOT to lubricate guides with any oil or grease.** It is advisable to occasionally clean the guides with spirit cleaner to remove any dust particles.



GLIDEROL GARAGE DOORS LTD
DAVY DRIVE, NORTH WEST INDUSTRIAL ESTATE,
PETERLEE, COUNTY DURHAM SR8 2JF
Telephone: 0191 518 0455 • Fax: 0191 518 0548
e-mail: info@gliderol.co.uk
www.gliderol.co.uk